

OPERATING INSTRUCTIONS **HIDE-A-BENCH**[®] (1 TIER UNIT)

FOLDING IN **HIDE-A-BENCH**[®]

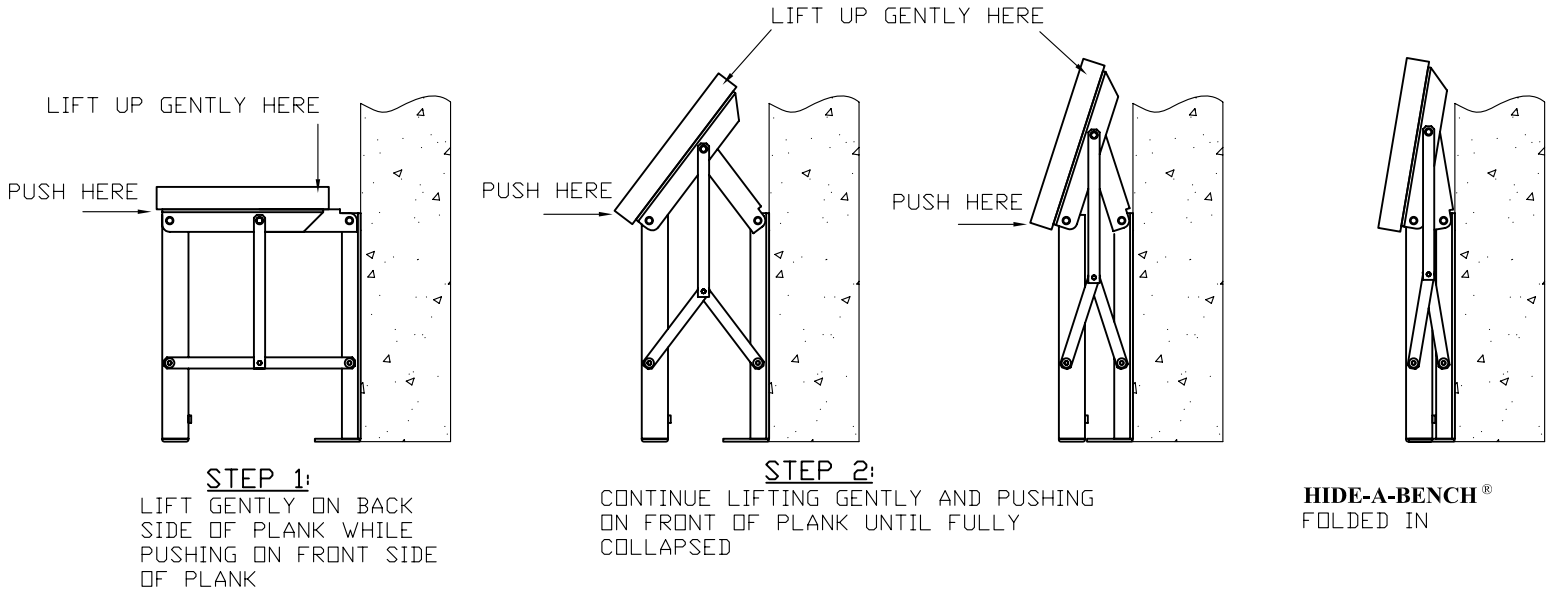

FOLDING OUT **HIDE-A-BENCH**[®]

STABILIZE BACK SIDE OF PLANK BY LIFTING SLIGHTLY TO KEEP FROM SLAMMING DOWN

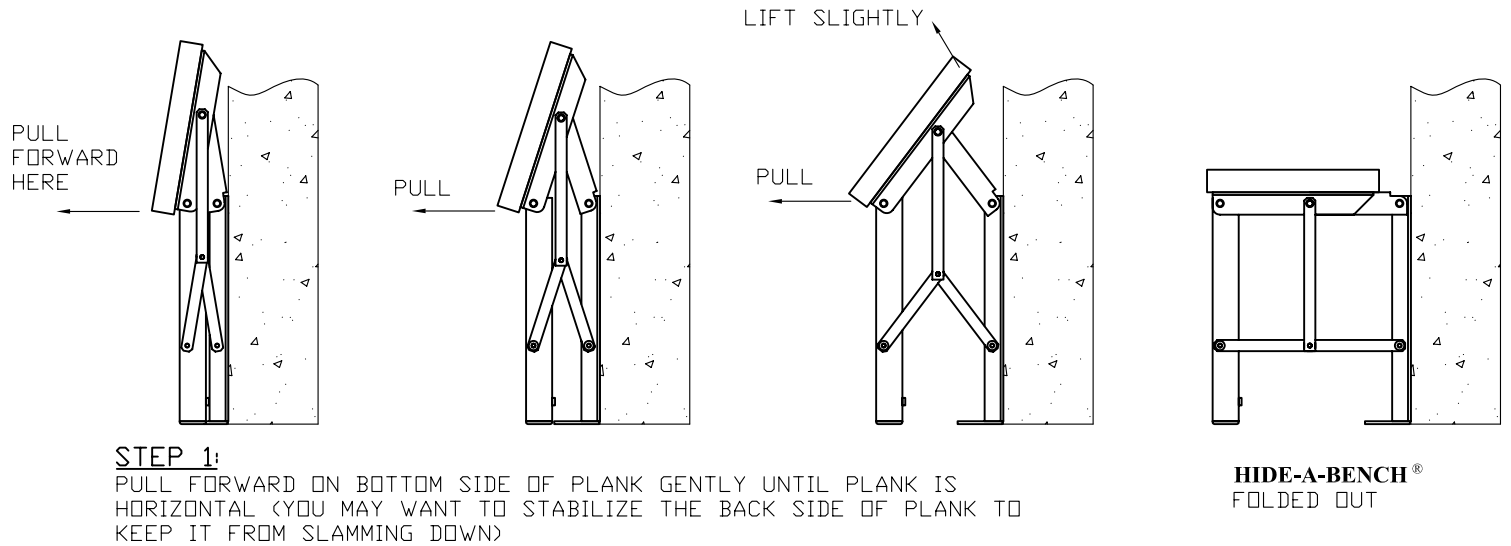

BENCH LENGTH	SUGGESTED PERSONS TO FOLD
9'	1
12'	2
15'	2
18'	2
21'	2



THE BEST SEAT IN THE HOUSE!
Tel 866-261-5337 Fax 775-822-1858
International Calls 860-621-7321
Email: Info@BuiltRiteBleachers.com

DATE: 01-11-08	DWG#: HAB_1TIER_17H_CUST_INST_REVNC	
DESCRIPTION: 1 TIER HIDE-A-BENCH [®] INSTRUCTIONS		
DRAWN BY: MJP	REV DATE:	DWG: _____ OF _____